



ETC Laboratories

ETC Laboratories
Corporate Offices / Laboratories
297 Buell Road
Rochester, NY 14624
(585) 328-7668
Fax: (585) 328-7777

Simulation Report (Revised)

Rendered To:

Showcase Custom Vinyl Windows
1002 Olde Towne Drive
Irving, TX 75061

Productline Series/Model

Series 700 Casement Window

Report Number

ETC-07-738-19424.1

Report Number: ETC-07-738-19424.1
 Job Number: ETC-08-738-20621-3
 Simulation Date: July 10, 2007
 Report Date: July 10, 2007
 Expiration Date: July 10, 2011
 Revision Date: February 19, 2008

NFRC 100-2004, 200-2004, 500-2004 Simulation Report

Rendered To:

Showcase Custom Vinyl Windows
 1002 Olde Towne Drive
 Irving, TX 75061

Product Series/Model	Operating Type	Model Size (mm x mm)
Series 700 Casement Window	Casement - Single, X	600 x 1500

Validation Test Unit Description*

Item	Unit	Value
Frame type	-	VY
Sash type	-	VA
Overall width	in.	23.62
Overall height	in.	59.06
Overall IG nominal thickness	-	0.750
Number of glazing layers	-	2
Glass type	-	Float
Glass 1 thickness	in.	0.118
Glass 2 thickness	in.	0.118
Glass 3 thickness	in.	-
Spacer type	-	A8-D
Gap 1 thickness	in.	0.514
Gap 2 thickness	in.	-
Low-e emissivity	-	0.036
Low-e surface	-	2
IG gap fill	-	AIR
Percent gap fill	-	-

* Aluminum reinforcements in all sash members.

Validation Test Unit U-factor

Item	Unit	Value
Simulated U-Factor	Btu/hr-ft ² -°F	0.33

Notes: The validation unit was submitted by Showcase Custom Vinyl Windows.

NFRC 100-2004 (U-factor), 200-2004 (SHGC and VT), and 500-2004 (CR-value) Productline Matrix

Manufacturer Name: Showcase Custom Vinyl Windows
 Product Series / Model: Series 700 Casement Window
 Operator Type: Casement - Single, X
 Frame Type: VY
 Sash Type: VY

Job Number: ETC-08-738-20621-3
 Sim Lab Code: SETC
 Model Size (mm x mm) 600 x 1500
 Thermal Break Type:

Report Number: ETC-07-738-19424.1

Product Number	Grouping ID Number	Overall IG Thickness	Pane Thickness #[1]	Pane Thickness #[2]	Pane Thickness #[3]	Gap 1	Gap 2	Gap Fill 1	% of Gap fill 1	Gap Fill 2	% of Gap fill 1	Spacer	Emissivity Surface 1	Emissivity Surface 2	Emissivity Surface 3	Emissivity Surface 4	Emissivity Surface 5	Emissivity Surface 6	Tint	C-O-G U-factor	C-O-G SHGC	C-O-G VT	Grid Type	Grid Size	Total Product U-factor	CR - Value	Total Product SHGC	Total Product VT	Additional Comments
001	00	0.750	0.098	0.098		0.553		AIR				A8-D	0.036							0.30	0.37	0.70	N		0.31	58	0.27	0.50	RLE/Clr
	01	0.750	0.098	0.098		0.553		AIR				A8-D	0.036							0.30	0.37	0.70	G	< 1"	0.31	58	0.24	0.45	
	02	0.750	0.098	0.098		0.553		AIR				A8-D	0.036							0.30	0.37	0.70	S	>1"	0.31	58	0.22	0.41	
	03	0.750	0.118	0.118		0.514		AIR				A8-D	0.036							0.30	0.37	0.70	N		0.31	58	0.26	0.49	RLE/Clr
	04	0.750	0.118	0.118		0.514		AIR				A8-D	0.036							0.30	0.37	0.70	G	< 1"	0.31	58	0.24	0.45	
	05	0.750	0.118	0.118		0.514		AIR				A8-D	0.036							0.30	0.37	0.70	S	>1"	0.31	58	0.22	0.40	
002	00	0.750	0.098	0.098		0.553		ARG	90			A8-D	0.036							0.25	0.36	0.70	N		0.28	61	0.26	0.50	RLE/Clr, Arg
	01	0.750	0.098	0.098		0.553		ARG	90			A8-D	0.036							0.25	0.36	0.70	G	< 1"	0.28	61	0.24	0.45	
	02	0.750	0.098	0.098		0.553		ARG	90			A8-D	0.036							0.25	0.36	0.70	S	>1"	0.28	61	0.22	0.41	
	03	0.750	0.118	0.118		0.514		ARG	90			A8-D	0.036							0.25	0.36	0.70	N		0.28	61	0.26	0.49	RLE/Clr, Arg
	04	0.750	0.118	0.118		0.514		ARG	90			A8-D	0.036							0.25	0.36	0.70	G	< 1"	0.28	61	0.24	0.45	
	05	0.750	0.118	0.118		0.514		ARG	90			A8-D	0.036							0.25	0.36	0.70	S	>1"	0.28	61	0.22	0.40	
003	00	0.750	0.197	0.197		0.356		AIR				A8-D	0.036							0.33	0.37	0.68	N		0.34	53	0.27	0.48	RLE/Clr
	01	0.750	0.197	0.197		0.356		AIR				A8-D	0.036							0.33	0.37	0.68	S	>1"	0.34	53	0.22	0.40	
004	00	0.750	0.197	0.197		0.356		AIR				A8-D	0.036							0.33	0.37	0.68	G	< 1"	0.35	53	0.24	0.44	

Report Number: ETC-07-738-19424.1

Product Number	Grouping ID Number	Overall IG Thickness	Pane Thickness #[1]	Pane Thickness #[2]	Pane Thickness #[3]	Gap 1	Gap 2	Gap Fill 1	% of Gap fill 1	Gap Fill 2	% of Gap fill 1	Spacer	Emissivity Surface 1	Emissivity Surface 2	Emissivity Surface 3	Emissivity Surface 4	Emissivity Surface 5	Emissivity Surface 6	Tint	C-O-G U-factor	C-O-G SHGC	C-O-G VT	Grid Type	Grid Size	Total Product U-factor	CR - Value	Total Product SHGC	Total Product VT	Additional Comments
----------------	--------------------	----------------------	---------------------	---------------------	---------------------	-------	-------	------------	-----------------	------------	-----------------	--------	----------------------	----------------------	----------------------	----------------------	----------------------	----------------------	------	----------------	------------	----------	-----------	-----------	------------------------	------------	--------------------	------------------	---------------------

005	00	0.750	0.197	0.197		0.356		ARG	90			A8-D	0.036							0.27	0.36	0.68	N		0.29	58	0.26	0.48	RLE/Clr, Arg
	01	0.750	0.197	0.197		0.356		ARG	90			A8-D	0.036							0.27	0.36	0.68	S	>1"	0.29	58	0.22	0.40	
006	00	0.750	0.197	0.197		0.356		ARG	90			A8-D	0.036							0.27	0.36	0.68	G	< 1"	0.31	58	0.24	0.44	
007	00	0.750	0.118	0.315		0.317		AIR				A8-D	0.036							0.35	0.36	0.68	N		0.34	53	0.26	0.48	RLE/060-Lami
	01	0.750	0.118	0.315		0.317		AIR				A8-D	0.036							0.35	0.36	0.68	S	>1"	0.34	53	0.22	0.39	
	02	0.750	0.118	0.266		0.366		AIR				A8-D	0.036							0.32	0.36	0.68	N		0.34	53	0.26	0.48	RLE/030-Lami
	03	0.750	0.118	0.266		0.366		AIR				A8-D	0.036							0.32	0.36	0.68	S	>1"	0.34	53	0.22	0.39	
	04	0.750	0.118	0.315		0.317		AIR				A8-D	0.036							0.34	0.36	0.67	N		0.34	53	0.26	0.48	RLE/090-Lami
	05	0.750	0.118	0.315		0.317		AIR				A8-D	0.036							0.34	0.36	0.67	S	>1"	0.34	53	0.22	0.39	
008	00	0.750	0.118	0.315		0.317		AIR				A8-D	0.036							0.35	0.36	0.68	G	< 1"	0.36	53	0.24	0.44	
	01	0.750	0.118	0.266		0.366		AIR				A8-D	0.036							0.32	0.36	0.68	G	< 1"	0.36	53	0.24	0.44	
	02	0.750	0.118	0.315		0.317		AIR				A8-D	0.036							0.34	0.36	0.67	G	< 1"	0.36	53	0.24	0.43	
009	00	0.750	0.118	0.315		0.317		ARG	90			A8-D	0.036							0.28	0.36	0.68	N		0.30	58	0.26	0.48	RLE/060-Lami, Arg
	01	0.750	0.118	0.315		0.317		ARG	90			A8-D	0.036							0.28	0.36	0.68	S	>1"	0.30	58	0.22	0.39	
	02	0.750	0.118	0.266		0.366		ARG	90			A8-D	0.036							0.26	0.36	0.68	N		0.30	58	0.26	0.48	RLE/030-Lami, Arg
	03	0.750	0.118	0.266		0.366		ARG	90			A8-D	0.036							0.26	0.36	0.68	S	>1"	0.30	58	0.22	0.39	
	04	0.750	0.118	0.315		0.317		ARG	90			A8-D	0.036							0.28	0.36	0.67	N		0.30	58	0.26	0.48	RLE/090-Lami, Arg
	05	0.750	0.118	0.315		0.317		ARG	90			A8-D	0.036							0.28	0.36	0.67	S	>1"	0.30	58	0.22	0.39	
010	00	0.750	0.118	0.315		0.317		ARG	90			A8-D	0.036							0.28	0.36	0.68	G	< 1"	0.31	58	0.24	0.44	
	01	0.750	0.118	0.266		0.366		ARG	90			A8-D	0.036							0.26	0.36	0.68	G	< 1"	0.31	58	0.24	0.44	

Report Number: ETC-07-738-19424.1

Product Number	Grouping ID Number	Overall IG Thickness	Pane Thickness #[1]	Pane Thickness #[2]	Pane Thickness #[3]	Gap 1	Gap 2	Gap Fill 1	% of Gap fill 1	Gap Fill 2	% of Gap fill 1	Spacer	Emissivity Surface 1	Emissivity Surface 2	Emissivity Surface 3	Emissivity Surface 4	Emissivity Surface 5	Emissivity Surface 6	Tint	C-O-G U-factor	C-O-G SHGC	C-O-G VT	Grid Type	Grid Size	Total Product U-factor	CR - Value	Total Product SHGC	Total Product VT	Additional Comments
----------------	--------------------	----------------------	---------------------	---------------------	---------------------	-------	-------	------------	-----------------	------------	-----------------	--------	----------------------	----------------------	----------------------	----------------------	----------------------	----------------------	------	----------------	------------	----------	-----------	-----------	------------------------	------------	--------------------	------------------	---------------------

	02	0.750	0.118	0.315		0.317		ARG	90			A8-D	0.036							0.28	0.36	0.67	G	< 1"	0.31	58	0.24	0.43	
--	----	-------	-------	-------	--	-------	--	-----	----	--	--	------	-------	--	--	--	--	--	--	------	------	------	---	------	------	----	------	------	--

011	00	0.750	0.098	0.098		0.553		AIR				A8-D	0.042							0.30	0.42	0.73	N		0.31	58	0.30	0.52	EE272/Clr
	01	0.750	0.098	0.098		0.553		AIR				A8-D	0.042							0.30	0.42	0.73	G	< 1"	0.31	58	0.28	0.47	
	04	0.750	0.098	0.098		0.553		AIR				A8-D	0.042							0.30	0.42	0.73	S	>1"	0.31	58	0.25	0.42	
	05	0.750	0.098	0.098		0.553		AIR				A8-D	0.022							0.29	0.28	0.65	N		0.31	58	0.20	0.46	EE366/Clr
	06	0.750	0.098	0.098		0.553		AIR				A8-D	0.022							0.29	0.28	0.65	G	< 1"	0.31	58	0.19	0.42	
	09	0.750	0.098	0.098		0.553		AIR				A8-D	0.022							0.29	0.28	0.65	S	>1"	0.31	58	0.17	0.38	
	10	0.750	0.118	0.118		0.514		AIR				A8-D	0.042							0.30	0.42	0.72	N		0.31	58	0.30	0.51	EE272/Clr
	11	0.750	0.118	0.118		0.514		AIR				A8-D	0.042							0.30	0.42	0.72	G	< 1"	0.31	58	0.27	0.46	
	14	0.750	0.118	0.118		0.514		AIR				A8-D	0.042							0.30	0.42	0.72	S	>1"	0.31	58	0.25	0.42	
	15	0.750	0.118	0.118		0.514		AIR				A8-D	0.022							0.29	0.28	0.65	N		0.31	58	0.20	0.46	EE366/Clr
	16	0.750	0.118	0.118		0.514		AIR				A8-D	0.022							0.29	0.28	0.65	G	< 1"	0.31	58	0.19	0.42	
	19	0.750	0.118	0.118		0.514		AIR				A8-D	0.022							0.29	0.28	0.65	S	>1"	0.31	58	0.17	0.37	
012	00	0.750	0.098	0.098		0.553		ARG	90			A8-D	0.042							0.25	0.42	0.73	N		0.28	61	0.30	0.52	EE272/Clr, Arg
	01	0.750	0.098	0.098		0.553		ARG	90			A8-D	0.042							0.25	0.42	0.73	G	< 1"	0.28	61	0.28	0.47	
	04	0.750	0.098	0.098		0.553		ARG	90			A8-D	0.042							0.25	0.42	0.73	S	>1"	0.28	61	0.25	0.42	
	05	0.750	0.098	0.098		0.553		ARG	90			A8-D	0.022							0.25	0.27	0.65	N		0.28	61	0.20	0.46	EE366/Clr, Arg
	06	0.750	0.098	0.098		0.553		ARG	90			A8-D	0.022							0.25	0.27	0.65	G	< 1"	0.28	61	0.18	0.42	
	09	0.750	0.098	0.098		0.553		ARG	90			A8-D	0.022							0.25	0.27	0.65	S	>1"	0.28	61	0.17	0.38	
	10	0.750	0.118	0.118		0.514		ARG	90			A8-D	0.042							0.25	0.41	0.72	N		0.28	61	0.30	0.51	EE272/Clr, Arg

Report Number: ETC-07-738-19424.1

Product Number	Grouping ID Number	Overall IG Thickness	Pane Thickness #[1]	Pane Thickness #[2]	Pane Thickness #[3]	Gap 1	Gap 2	Gap Fill 1	% of Gap fill 1	Gap Fill 2	% of Gap fill 1	Spacer	Emissivity Surface 1	Emissivity Surface 2	Emissivity Surface 3	Emissivity Surface 4	Emissivity Surface 5	Emissivity Surface 6	Tint	C-O-G U-factor	C-O-G SHGC	C-O-G VT	Grid Type	Grid Size	Total Product U-factor	CR - Value	Total Product SHGC	Total Product VT	Additional Comments
----------------	--------------------	----------------------	---------------------	---------------------	---------------------	-------	-------	------------	-----------------	------------	-----------------	--------	----------------------	----------------------	----------------------	----------------------	----------------------	----------------------	------	----------------	------------	----------	-----------	-----------	------------------------	------------	--------------------	------------------	---------------------

	11	0.750	0.118	0.118		0.514		ARG	90			A8-D	0.042							0.25	0.41	0.72	G	< 1"	0.28	61	0.27	0.46	
	14	0.750	0.118	0.118		0.514		ARG	90			A8-D	0.042							0.25	0.41	0.72	S	>1"	0.28	61	0.25	0.42	
	15	0.750	0.118	0.118		0.514		ARG	90			A8-D	0.022							0.24	0.27	0.65	N		0.28	61	0.20	0.46	EE366/Clr, Arg
	16	0.750	0.118	0.118		0.514		ARG	90			A8-D	0.022							0.24	0.27	0.65	G	< 1"	0.28	61	0.18	0.42	
	19	0.750	0.118	0.118		0.514		ARG	90			A8-D	0.022							0.24	0.27	0.65	S	>1"	0.28	61	0.17	0.37	
013	00	0.750	0.197	0.197		0.356		AIR				A8-D	0.042							0.33	0.41	0.71	N		0.34	53	0.30	0.50	EE272/Clr
	01	0.750	0.197	0.197		0.356		AIR				A8-D	0.042							0.33	0.41	0.71	S	>1"	0.34	53	0.25	0.41	
	02	0.750	0.197	0.197		0.356		AIR				A8-D	0.022							0.32	0.28	0.64	N		0.34	53	0.21	0.45	EE366/Clr
	03	0.750	0.197	0.197		0.356		AIR				A8-D	0.022							0.32	0.28	0.64	S	>1"	0.34	53	0.17	0.37	
014	00	0.750	0.197	0.197		0.356		AIR				A8-D	0.042							0.33	0.41	0.71	G	< 1"	0.35	53	0.27	0.45	
	01	0.750	0.197	0.197		0.356		AIR				A8-D	0.022							0.32	0.28	0.64	G	< 1"	0.35	53	0.19	0.41	
015	00	0.750	0.197	0.197		0.356		ARG	90			A8-D	0.042							0.27	0.41	0.71	N		0.30	58	0.30	0.50	EE272/Clr, Arg
	01	0.750	0.197	0.197		0.356		ARG	90			A8-D	0.042							0.27	0.41	0.71	S	>1"	0.30	58	0.25	0.41	
	02	0.750	0.197	0.197		0.356		ARG	90			A8-D	0.022							0.26	0.28	0.64	N		0.30	58	0.20	0.45	EE366/Clr, Arg
	03	0.750	0.197	0.197		0.356		ARG	90			A8-D	0.022							0.26	0.28	0.64	S	>1"	0.30	58	0.17	0.37	
016	00	0.750	0.197	0.197		0.356		ARG	90			A8-D	0.042							0.27	0.41	0.71	G	< 1"	0.31	58	0.27	0.45	
	01	0.750	0.197	0.197		0.356		ARG	90			A8-D	0.022							0.26	0.28	0.64	G	< 1"	0.31	58	0.19	0.41	
017	00	0.750	0.118	0.315		0.317		AIR				A8-D	0.042							0.35	0.41	0.70	N		0.35	53	0.30	0.50	EE272/060-Lami
	01	0.750	0.118	0.315		0.317		AIR				A8-D	0.042							0.35	0.41	0.70	S	>1"	0.35	53	0.25	0.41	
	02	0.750	0.118	0.266		0.366		AIR				A8-D	0.042							0.32	0.41	0.70	N		0.35	53	0.30	0.50	EE272/030-Lami

Report Number: ETC-07-738-19424.1

Product Number	Grouping ID Number	Overall IG Thickness	Pane Thickness #[1]	Pane Thickness #[2]	Pane Thickness #[3]	Gap 1	Gap 2	Gap Fill 1	% of Gap fill 1	Gap Fill 2	% of Gap fill 1	Spacer	Emissivity Surface 1	Emissivity Surface 2	Emissivity Surface 3	Emissivity Surface 4	Emissivity Surface 5	Emissivity Surface 6	Tint	C-O-G U-factor	C-O-G SHGC	C-O-G VT	Grid Type	Grid Size	Total Product U-factor	CR - Value	Total Product SHGC	Total Product VT	Additional Comments
----------------	--------------------	----------------------	---------------------	---------------------	---------------------	-------	-------	------------	-----------------	------------	-----------------	--------	----------------------	----------------------	----------------------	----------------------	----------------------	----------------------	------	----------------	------------	----------	-----------	-----------	------------------------	------------	--------------------	------------------	---------------------

	03	0.750	0.118	0.266		0.366		AIR				A8-D	0.042							0.32	0.41	0.70	S	>1"	0.35	53	0.25	0.41	
	04	0.750	0.118	0.315		0.317		AIR				A8-D	0.042							0.35	0.41	0.70	N		0.35	53	0.30	0.49	EE272/090-Lami
	05	0.750	0.118	0.315		0.317		AIR				A8-D	0.042							0.35	0.41	0.70	S	>1"	0.35	53	0.25	0.40	
	06	0.750	0.118	0.315		0.317		AIR				A8-D	0.022							0.34	0.28	0.63	N		0.35	53	0.20	0.45	EE366/060-Lami
	07	0.750	0.118	0.315		0.317		AIR				A8-D	0.022							0.34	0.28	0.63	S	>1"	0.35	53	0.17	0.37	
	08	0.750	0.118	0.266		0.366		AIR				A8-D	0.022							0.32	0.28	0.63	N		0.35	53	0.20	0.45	EE366/030-Lami
	09	0.750	0.118	0.266		0.366		AIR				A8-D	0.022							0.32	0.28	0.63	S	>1"	0.35	53	0.17	0.37	
	10	0.750	0.118	0.315		0.317		AIR				A8-D	0.022							0.34	0.28	0.63	N		0.35	53	0.20	0.44	EE366/090-Lami
	11	0.750	0.118	0.315		0.317		AIR				A8-D	0.022							0.34	0.28	0.63	S	>1"	0.35	53	0.17	0.36	
018	00	0.750	0.118	0.315		0.317		AIR				A8-D	0.042							0.35	0.41	0.70	G	<1"	0.36	53	0.27	0.45	
	01	0.750	0.118	0.266		0.366		AIR				A8-D	0.042							0.32	0.41	0.70	G	<1"	0.36	53	0.27	0.45	
	02	0.750	0.118	0.315		0.317		AIR				A8-D	0.042							0.35	0.41	0.70	G	<1"	0.36	53	0.27	0.45	
	03	0.750	0.118	0.315		0.317		AIR				A8-D	0.022							0.34	0.28	0.63	G	<1"	0.36	53	0.19	0.41	
	04	0.750	0.118	0.266		0.366		AIR				A8-D	0.022							0.32	0.28	0.63	G	<1"	0.36	53	0.19	0.41	
	05	0.750	0.118	0.315		0.317		AIR				A8-D	0.022							0.34	0.28	0.63	G	<1"	0.36	53	0.19	0.40	
019	00	0.750	0.118	0.315		0.317		ARG	90			A8-D	0.042							0.28	0.41	0.70	N		0.30	58	0.30	0.50	EE272/060-Lami, Arg
	01	0.750	0.118	0.315		0.317		ARG	90			A8-D	0.042							0.28	0.41	0.70	S	>1"	0.30	58	0.25	0.41	
	02	0.750	0.118	0.266		0.366		ARG	90			A8-D	0.042							0.26	0.41	0.70	N		0.30	58	0.30	0.50	EE272/030-Lami, Arg
	03	0.750	0.118	0.266		0.366		ARG	90			A8-D	0.042							0.26	0.41	0.70	S	>1"	0.30	58	0.25	0.41	
	04	0.750	0.118	0.315		0.317		ARG	90			A8-D	0.042							0.28	0.41	0.70	N		0.30	58	0.30	0.49	EE272/090-Lami, Arg

Report Number: ETC-07-738-19424.1

Product Number	Grouping ID Number	Overall IG Thickness	Pane Thickness #[1]	Pane Thickness #[2]	Pane Thickness #[3]	Gap 1	Gap 2	Gap Fill 1	% of Gap fill 1	Gap Fill 2	% of Gap fill 1	Spacer	Emissivity Surface 1	Emissivity Surface 2	Emissivity Surface 3	Emissivity Surface 4	Emissivity Surface 5	Emissivity Surface 6	Tint	C-O-G U-factor	C-O-G SHGC	C-O-G VT	Grid Type	Grid Size	Total Product U-factor	CR - Value	Total Product SHGC	Total Product VT	Additional Comments
----------------	--------------------	----------------------	---------------------	---------------------	---------------------	-------	-------	------------	-----------------	------------	-----------------	--------	----------------------	----------------------	----------------------	----------------------	----------------------	----------------------	------	----------------	------------	----------	-----------	-----------	------------------------	------------	--------------------	------------------	---------------------

	05	0.750	0.118	0.315		0.317		ARG	90			A8-D	0.042							0.28	0.41	0.70	S	>1"	0.30	58	0.25	0.40	
	06	0.750	0.118	0.315		0.317		ARG	90			A8-D	0.022							0.27	0.28	0.63	N		0.30	58	0.20	0.45	EE366/060-Lami, Arg
	07	0.750	0.118	0.315		0.317		ARG	90			A8-D	0.022							0.27	0.28	0.63	S	>1"	0.30	58	0.17	0.37	
	08	0.750	0.118	0.266		0.366		ARG	90			A8-D	0.022							0.25	0.27	0.63	N		0.30	58	0.20	0.45	EE366/030-Lami, Arg
	09	0.750	0.118	0.266		0.366		ARG	90			A8-D	0.022							0.25	0.27	0.63	S	>1"	0.30	58	0.17	0.37	
	10	0.750	0.118	0.315		0.317		ARG	90			A8-D	0.022							0.27	0.27	0.63	N		0.30	58	0.20	0.44	EE366/090-Lami, Arg
	11	0.750	0.118	0.315		0.317		ARG	90			A8-D	0.022							0.27	0.27	0.63	S	>1"	0.30	58	0.17	0.36	
020	00	0.750	0.118	0.315		0.317		ARG	90			A8-D	0.042							0.28	0.41	0.70	G	<1"	0.32	58	0.27	0.45	
	01	0.750	0.118	0.266		0.366		ARG	90			A8-D	0.042							0.26	0.41	0.70	G	<1"	0.32	58	0.27	0.45	
	02	0.750	0.118	0.315		0.317		ARG	90			A8-D	0.042							0.28	0.41	0.70	G	<1"	0.32	58	0.27	0.45	
	03	0.750	0.118	0.315		0.317		ARG	90			A8-D	0.022							0.27	0.28	0.63	G	<1"	0.32	58	0.18	0.41	
	04	0.750	0.118	0.266		0.366		ARG	90			A8-D	0.022							0.25	0.27	0.63	G	<1"	0.32	58	0.18	0.41	
	05	0.750	0.118	0.315		0.317		ARG	90			A8-D	0.022							0.27	0.27	0.63	G	<1"	0.32	58	0.18	0.40	

Comments : Single Casement window with vinyl frame.
 No reinforcements.
 ARG - Argon with Single Probe filling method.
 A8-D - Duraseal Spacer - Dual Sealed.
 N - Products with no internal grids.
 G (Grid Size: <1") - Products with 0.188" x 0.802" size internal grids.
 S - Products with 1.121" size simulated divided lites.
 Low-e: 0.036 - Acclimate RLE 70/36 (Guardian); 0.042 - LoE²-272 (Cardinal IG); 0.022 - LoE³-366 (Cardinal IG)

Revision History: ETC-07-738-19424.1 - Options 011 - 020 were added.

Specialty Products

Series 700 Casement Window

Report Number: ETC-07-738-19424.1

	No Dividers	Divider <1"	Divider >1"
SHGC0	0.006	0.008	0.010
SHGC1	0.714	0.650	0.588
VT0	0.000	0.000	0.000
VT1	0.709	0.642	0.578

$$SHGC = SHGC_0 + SHGC_c * (SHGC_1 - SHGC_0)$$

$$VT = VT_0 + VT_c * (VT_1 - VT_0)$$

Where $SHGC_c$ = Center of Glass Solar Heat Gain Coefficient
& VT_c = Center of Glass Visible transmittance

Modeling Assumptions

1. Grouping Performed: 1) Center-of-Glazing

Product Description

Series 700 Casement Window

Report Number: ETC-07-738-19424.1

Frame:

Size (mm)	600 x 1500
Material	Vinyl - Rigid
Glazing Method	
Glazing Sealant	

Sash (1):

Operation Type	Projecting Out
Material	Vinyl - Rigid
Glazing Method	Exterior Glazed
Glazing Sealant	Silicone

Sash (2):

Operation Type	
Material	
Glazing Method	
Glazing Sealant	

Reinforcement Material & Locations:

No reinforcements.

Weatherstripping Type and Locations:

Leaf and bulb seal weatherstripping in all sash members.

Others:

ARG - Argon with Single Probe filling method.

A8-D - Duraseal Spacer - Dual Sealed.

Low-e: 0.036 - Acclimate RLE 70/36 (Guardian); 0.042 - LoE²-272 (Cardinal IG); 0.022 - LoE³-366 (Cardinal IG)

This report, in its original form contains product drawings and a Bill of Materials.

Report Number: ETC-07-738-19424.1

Conditions, Terms, and General Notes Regarding The Simulation

The individual products were simulated in full accordance with NFRC 100-2004, 200-2004 & 500-2004, using NFRC approved programs Window 5.2 and THERM 5.2. All window specifications were received from drawings and bill of materials supplied by the manufacturer. This report may not be reproduced except in full, without the approval of ETC Laboratories. This report relates only to the items simulated. Rounding is per NFRC unit conversion and rounding Policy. **The rating values included in this report are for submittal to an NFRC-licensed IA and not meant to be used directly for labeling purposes.** Only those values identified on a valid Certification Authorization Report (CAR) by an NFRC accredited Inspection Agency (IA) are to be used for labeling purposes.

ETC Laboratories makes no opinions or endorsements regarding this product and its performance. ETC Laboratories letters, reports, its name or insignia or mark are for the exclusive use of the client so named herein and any other use is strictly prohibited. The report, letters and the name of ETC Laboratories, its seal or mark shall not be used in any circumstance to the public or in any advertising.

Limitation of Liability: Due diligence was used in rendering the professional opinion. By acceptance of this report, the client agrees to hold harmless and indemnify ETC Laboratories, Inc. from and against all liability, claims, and demands of any kind whatsoever, which arise out of or in any manner connected with the performance of the work referred to herein.

FOR ETC LABORATORIES

Michael Cooper
Simulation Technician, NFRC Certified Simulator
Thermal Simulation Department

Gurjinder Singh
Simulator-in-Responsible Charge, NFRC Certified Simulator
Thermal Simulation Department

THIS MATERIAL IS PROPRIETARY AND CONFIDENTIAL TO VINYL BUILDING PRODUCTS INC. AND SHALL NOT BE REPRODUCED, COPIED OR DISSEMINATED WITHOUT THE EXPRESSED, WRITTEN PERMISSION OF VINYL BUILDING PRODUCTS INC.											007B029 (SEE ASSEMBLY 007A016)	
BILL OF MATERIALS & SOURCES												
ITEM	NAME	SIZE	REQ	PROCESS.NO.	P/N OR MATERIAL/SOURCE	ITEM	NAME	SIZE	REQ	PROCESS.NO.	P/N OR MATERIAL/SOURCE	
1	JAMB		1	007P004	700/VBP	35						
2	JAMB (Lock side)		1	007P011	700/VBP	36	SNUBBER		1	007P128	H774(set: keeper & cam) / VBP	
3	HEAD		1	007P124	700/VBP	37						
4	SILL		1	007P115	701/VBP	38	SASH LOCK		1		16.41.xx.100/Truth	
5	SILL COVER		1	007P139	703/VBP	39	SASH KEEPER		1		31344-XX/Truth	
6	SCREEN SUB-ASSY		1	007P032	007S026	40						
7						41						
8	GLASS STOP	2H, 2V	4	007P019	706/VBP	42						
9	TOP RAIL		1	007P129	702/VBP	43						
10	BOTTOM RAIL		1	007P117	702/VBP	44	Misc. Screws:					
11	STILE (Lock side)		1	007P012	702/VBP	45	Operator	#8 x 3/4"	6		Flat Head/Merchants, SS	
12	STILE (Snubber side)		1	007P096	702/VBP	46	Stud Bracket	#8 x 3/4"	3		Flt.Hd.Undercut/Merchants, SS	
13						47						
14	I.G. UNIT	3/4"	1		007H001	48	Hinge Track	#7 x 1/2"	8pr		Fl.Hd.Undercut/Merchants, SS	
15	GLAZING BLOCK	15/16 sq. x .187	5	007G006	007H005	49	Hinge Arm	#7 x 1/2"	8pr		Flat Head/Merchants, SS	
16	Silicone		A/R		Silglaze II SCS2811-D1/GE; Schnee-Morehead 5733; Pecora 896	50	Sash Lock	#8 x 3/4"	2		Flat Head/Merchants, SS	
17						51	Sash Keeper	#8 x 3/4"	2		Flt.Hd.Undercut/Merchants, SS	
18						52	Snubber Kpr.	#7 x 3/4"	2		Flt.Hd.Undercut/Merchants, SS	
19	BULB SEAL	2H, 2V	4		PP629/Amesbury	53	Snubber Cam	#7 x 3/4"	2		Flt.Hd.Undercut/Merchants, SS	
20	SASH FLAP	2H, 2V	4		PP812/Amesbury	54						
21	HOLE PLUGS		A/R		9946/Ashland	55						
22						56	Options:					
23						57	GLASS STOP	2H, 2V	4	007P010	704/VBP	
24	OPERATOR		1		50.50.XX.XXX / Truth Maxim	58	I.G. UNIT	15/16"	1		007H001	
25	CRANK HANDLE		1		11454 / Truth Maxim Hrdwr.	59						
26	STUD BRACKET ASS'Y		1		12510.92 RH or 12511.92LH/Truth	60						
27	OPERATOR GASKET		1		31882 / Truth Maxim Hrdwr.	61						
28						62						
29						63						
30	HINGE (UL/LR)		1		14.97.00.005/Truth	64						9/26/02 -CTC
31	HINGE (LL/UR)		1		14.97.00.006/Truth							
32							VINYL BUILDING PRODUCTS, INC.					
33							700 SERIES CASEMENT					Rev. 09/08/04
34							REFER TO MAXIM SIZE CHART FOR UNIT SIZE SINGLE LOCK - MAXIM HDWR					ADDED SIZE CHART NOTE

THIS MATERIAL IS PROPRIETARY & CONFIDENTIAL TO VINYL BUILDING PRODUCTS INC. AND SHALL NOT BE REPRODUCED, COPIED OR DISSEMINATED WITHOUT THE EXPRESSED WRITTEN PERMISSION OF VINYL BUILDING PRODUCTS INCORPORATED.

B007A016

SECTION B-B

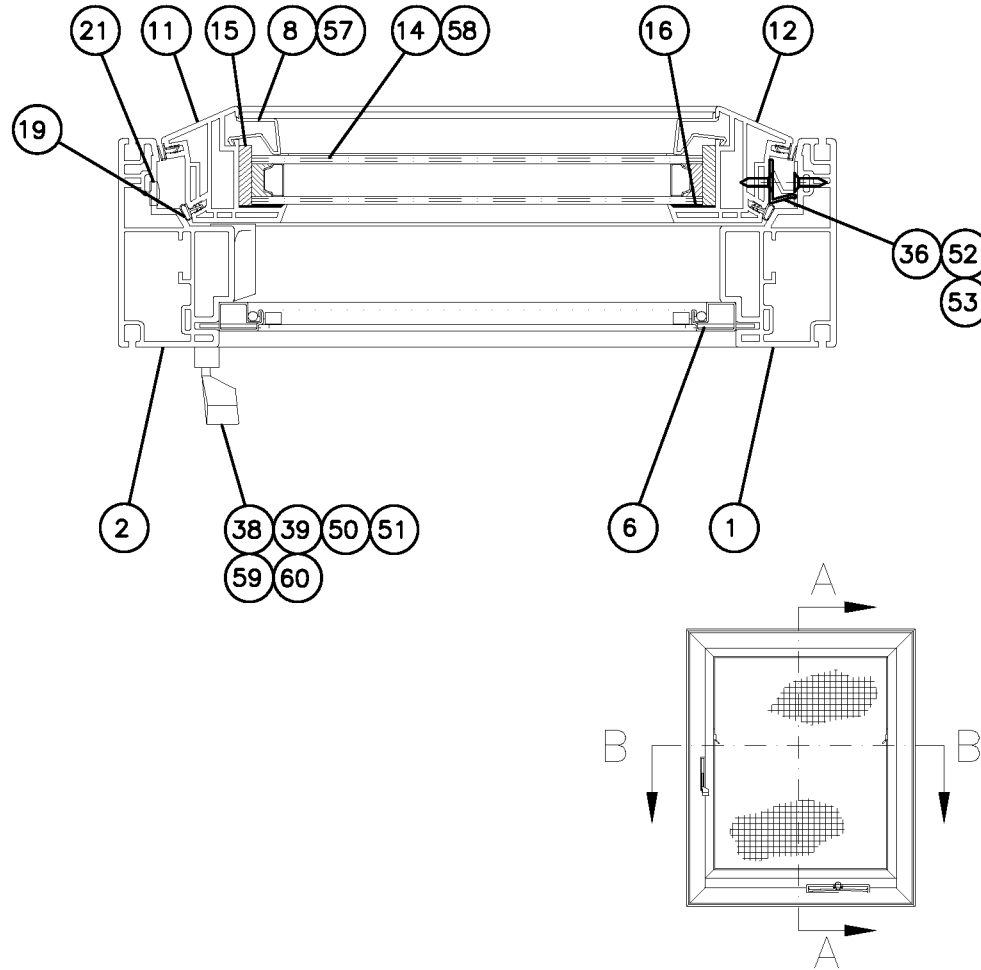

SECTION A-A

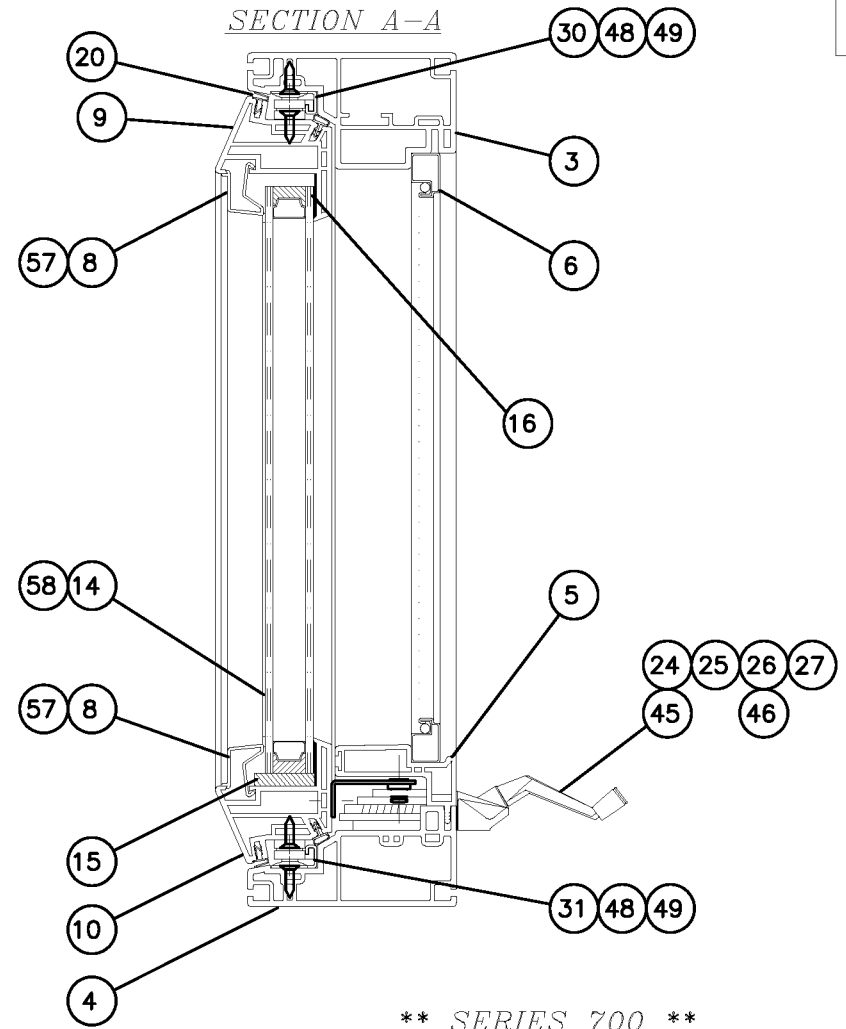

NOTE:
 1. SCALE: 1/2
 2. UPDATED: 09/13/02 ~CTC

**** SERIES 700 ****
**** CASEMENT WINDOW ****
*** UNDER 21" / SINGLE LOCK ***

REV	BY	APPV'D	DATE	CHANGE